

- Maximum lifting height : 6.05 m
- Capacity : 3400 kg
- Maximum forward reach : 3.25 m
- Torque convertor
- JSM : an «all in one» system

1) Hydraulic controls

2) Forward/Reverse selection

3) Speed selection (Powershift option)



MLT 634 Turbo LSU

Lifting capacity3400 kg
 (load centre at 500mm from forks heels)
 Tipping load at maximum reach2030 kg
 Tear out force with bucket to ISO 83135200 daN

Lifting height6.05 m
Times: unladen / loaded (in s)
 Lifting6.1/7.5
 Lowering5/4.6
 Boom extension5.2/6.2
 Boom retraction4.2/4.1
 Time unladen (in s)
 Crowd2.9
 Dump2.7

Tyres
 460/70-24/17,5 LR 24

Forks (mm)
 Length1200
 Width X thickness125 x 45
 Maximum distance between forks1260
 Carriage rotation146°

Multidisc brakes - hydraulically assisted on 4 wheels

Perkins engine STAGE III A
 Turbo: 1104 D - 44 TA4 cyl. - 4400 cm³
 Turbo 120: 1104 D - E 44 TA4 cyl. - 4400 cm³
 Puissance at 2200 tr/mn
 (ISO/TR 14396) Turbo101 HP/74.5 kw
 Turbo 120124 HP/91 kw
 Maximum torque: Turbo410 Nm at 1400 rpm
 Turbo 120490 Nm at 1400 rpm

Direct injection
 Water cooling

Transmissiontorque convertor
 Reversing shiftelectrohydraulic
TLSU/120 LSU :
 Powershuttle4/4
 Max. travel speed up to35 km/h*
120 LSU PS :
 Powershift6/3
 Max. travel speed up to40 km/h*

Hydraulic
Turbo LSU:108 l./mn - 270 bars
 Variable displacement pump
 Valve bank DDIC
 Monolever **J.S.M (Joystick Switch and Move)**
Turbo 120 LSU/120 LSU PS:149 l./mn - 270 bars
 Electronically regulated variable displacement pump
 Valve bank DDIC
 Monolever **J.S.M (Joystick Switch and Move)**
 Flow divider with load sensing device driving and braking

Capacities
 Hydraulic oil135 l.
 Fuel tank120 l.

Weight unladen (with forks)7025/7230 kg
Overall height2.30 m
Overall width2.40 m
Turning radius (outside wheels)3.77 m
Overall length4.58 m
Ground clearance0.44 m
Drawbar pullup to 9110 daN

Forward reach at maximum height : 0.75 m

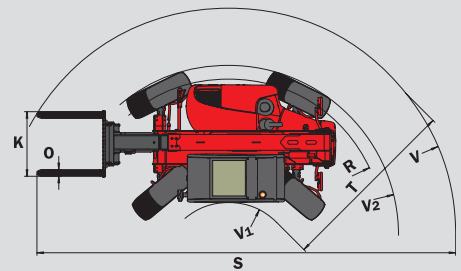
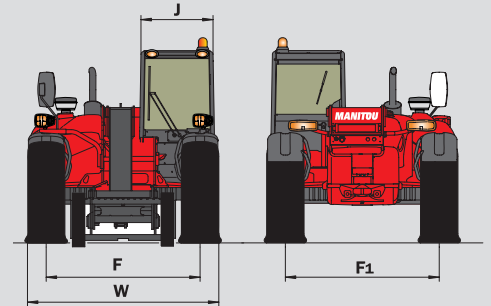
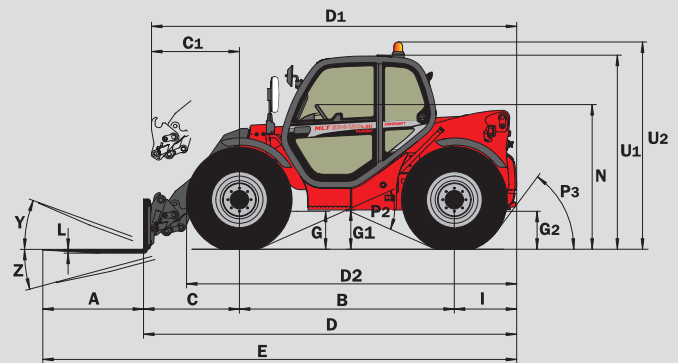
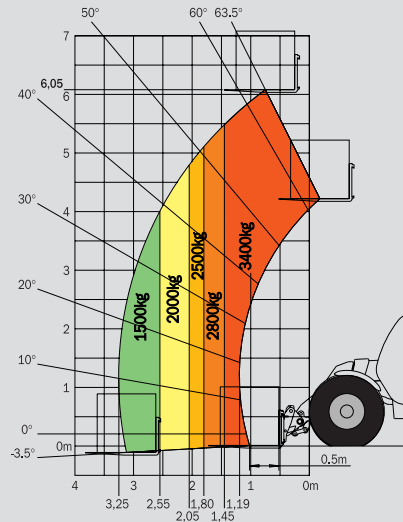

	MLT 634 T LSU MLT 634 - 120 LSU MLT 634 - 120 LSU PS
A	1200
B	2560
C	1141.9
C1	1245
D	4578.9
D1	4682
D2	4003
E	5778.9
F	1935
F1	1935
G	450
G1	435
G2	435
I	877
J	980
K	1260
L	45
N	1715
O	125
P2	47.5°
P3	53°
R	3535
S	7390.4
T	3450
U1	2300
U2	2550
V	4650
V1	1200
V2	3768.5
W	2402
Y	12°
Z	133.9°

mm



Operator shall conform with applicable regulation.
 * Can change according to the local regulation.

This publication in no way constitutes an offer and the company reserves the right to alter specification without prior notice.
 The MANITOU models presented in this brochure can be supplied complete with optional equipment attachments.

MANITOU BF SA
 B.P. 249 - 44158 Ancenis Cedex - France
 Tel. : 33 2 40 09 10 11 / Export Department Fax : 33 2 40 09 10 97
 www.manitou.com

700425EN-B - 02/09 - BE-496/Ind.B

