

# MANIACCESS

78 XE  
81 XE

Narrow and spacious



## 78 XE

 **Safe working load** .....230 kg including 2 people  
**On extension** .....110 kg including 1 person  
**Internal use** .....wind 0 km/h

 **Working height** .....7.75 m  
**Platform Height**.....5.75 m

 ① **Overall length** .....1.89 m  
 ② **Overall width**.....0.81 m  
 ③ **Overall height** .....2.11 m  
 ④ **Height with rails folded** .....1.76 m  
**Platform size**.....1.67 x 0.78 m  
**Platform extension size**.....0.90 m  
 ⑤ **Ground clearance**.....7.60 cm  
**Turning radius**  
 Inside.....0.05 m  
 ⑥ Outside.....1.70 m

 **Travel speed** .....0 to 4 Km/h  
**Lift/lower speed** .....14 s/20 s

 **Batteries** .....24 V/180 Ah (C5)  
 24 V/220 Ah (C20)  
 Integrated charger .....24 V/30 A

 **Gradeability** .....25%  
**Maximum slope**.....2°

 **Tyres (Solid non-marking)** .....14 x 4.5  
 2 wheel drive - 2 wheel steer

 **Weight**.....1380 kg

## 81 XE

 **Safe working load** .....340 kg including 2 people  
**On extension** .....120 kg including 1 person  
**Internal use** .....wind 0 km/h

 **Working height** .....8.10 m  
**Platform Height**.....6.10 m

 ① **Overall length** .....2.47 m  
 ② **Overall width**.....0.81 m  
 ③ **Overall height** .....2.14 m  
 ④ **Height with rails folded** .....1.92 m  
**Platform size**.....2.30 x 0.80 m  
**Platform extension size** .....1 m  
 ⑤ **Ground clearance** .....9.5 cm  
**Turning radius**  
 Inside : .....0.17 m  
 ⑥ Outside : .....2.10 m

 **Travel speed** .....0 to 4 Km/h  
**Lift/lower speed** .....21 s/33 s

 **Batteries** .....24 V/180 Ah (C5)  
 24 V/220 Ah (C20)  
 Integrated charger .....24 V/25 A

 **Gradeability** .....25%  
**Maximum slope**.....2°

 **Tyres (Solid non-marking)** .....16 x 5 x 11.1<sup>1/4</sup>  
 2 wheel drive - 2 wheel steer

 **Weight**.....1700 kg

### Standard Equipment

- Single beam lifting system with self lubricating pins
- Proportional controls
- Electronic controller for increased battery duty cycle
- Pot-hole safety system
- Removable control box
- Battery charge indicator
- Swing gate for easy access to platform
- Foldable guardrail (below 2 m)
- Hour meter
- 230 V predisposal
- Lifting brackets
- Forklift pockets
- Buscan technology
- Negative brake
- Diagnostic tool (LCD screen)

### Options

- Translation alarm
- All motion alarm
- Working lights
- Flashing beacon
- 230 V electric plug in platform
- Airline to the platform
- Load sensing system

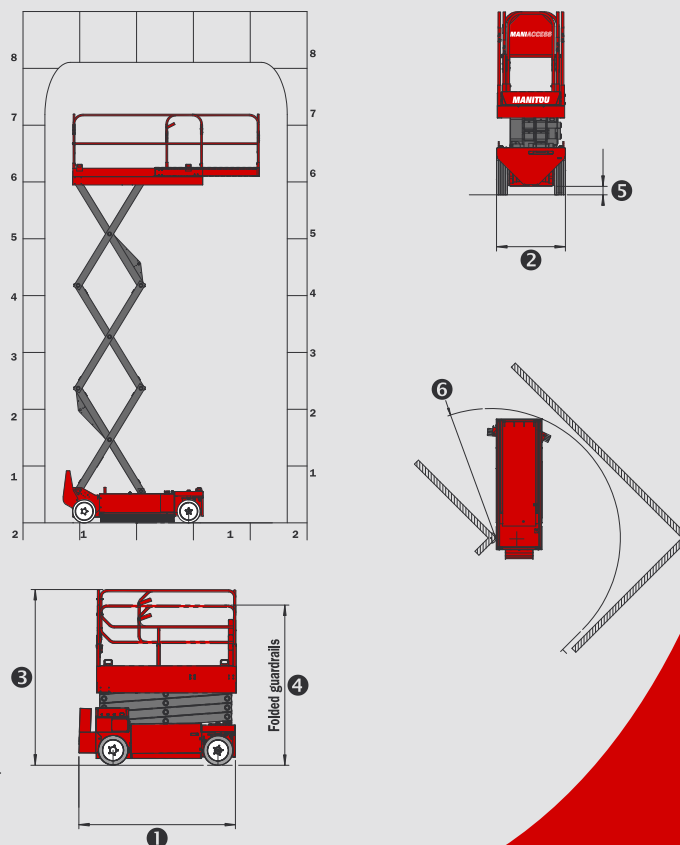

This publication in no way constitutes an offer and the company reserves the right to alter specification without prior notice. The MANITOU models presented in this brochure can be supplied complete with optional equipment attachments.



MANITOU BF SA

B.P. 249 - 44158 Ancenis Cedex - France  
 Tel. : 33 2 40 09 10 11 / Export Department Fax : 33 2 40 09 10 97  
 www.manitou.com

700173EN-B - 06/09

